

Elite™

Put yourself in control with an affordable Elite Lighting Control System



Full-featured lighting control is scaled perfectly for the midsize market with Centralite's affordable Elite™ System. Designed for residential or light commercial use, the Elite System can be used in a wide range of settings. From new houses to small businesses, Elite is packed with features equally suited for the homeowner or office manager.

Planned lighting creates a beautiful ambience and saves energy. Up to 60 scenes and 36 timed events can be stored to generate the exact lighting arrangement for every occasion. The resident astronomical clock automatically calculates day length throughout the year and adjusts lighting as needed. Intuitive, user-friendly PC-based software is included for system configuration. Built-in dimming scales back power consumption and extends bulb life. Centralite® also offers a number of options to further streamline your home or office lighting system.

The powerful Elite System subtly blends into any location. Excess wall clutter is eliminated with the use of intelligent low-profile keypads. The system doesn't even require special wall framing since the slim master control unit fits neatly into a standard stud-bay.

For the design conscious, keypads are available in a variety of colors and finishes to match any décor. Custom button engraving identifies which buttons control assigned activities.

In addition to lighting, the robust Elite System easily integrates with other automation systems including thermostats, security systems, ceiling fans, home entertainment, motorized gates and window blinds. Two RS-232 ports are included for connectivity to third-party products.

Specifications

ELITE PRODUCT FEATURES

- 48 Dimming loads provided in two 24-load panels
- Integrated Master Control Panel and STAR inputs
- Dimming method: Phase controlled
- 512 Dimming levels
- Standard Dimmer capacity: 8 AMPs per load/960 Watts; 16 AMPs per 4-load Relay Module; maximum panel load 72 AMPs per panel
- System wiring: CAT5
- Keypad/Control wiring: Low voltage
- System includes: 1 SuperSTAR input for up to 96 contact closure inputs; expandable to 192 inputs
- 3-Phase compatible
- 2 auxiliary ports available for optional Fan Speed Control Boards or Low Voltage Relay Boards
 - Up to 32 LVRB outputs
 - Up to 48 fan loads
- 2 RS-232 ports for third party connectivity
- Astronomical Real-Time Clock
- 60 Scenes: 57 programmable; 3 standard (All On/Off, Alarm Flash and Vacation)
- 36 timed events
- Power Requirements:
 - 120V Model: 60 Hz
 - 240V Model: 50 Hz
- Standard warranty: 5 year limited warranty from date of startup
- Regulatory/Safety Conformity: UL, C-Tick
- Title 24 Compliant

OPTIONAL FEATURES

- **A variety of Keypad options**
Please reference keypad spec sheets for available colors and button configurations.
- **Switch Status Terminal (SST)**
– provides whole home monitoring
- **Low Voltage Relay Board (LVRB)** – provides contact closure output; 16 relays per board (8 NO and 8 NO/NC)
- **Fan Speed Controller Board (FSCB)** – provides fan speed control for up to 4 Fan Loads per board; up to 6 FSCBs can be chained together per Auxiliary Port
- **IR Remote Control Receiver** – allows use of IR remotes conforming with the Philips/Marantz .pcf or .pcf command protocol to interface with the Elite Lighting Control System
- **Key Fob Remote**
- **JetPak** – Security and HVAC control
- **DMX-L Interface** – provides compatibility with DMX512-based lighting systems



Elite System Diagram

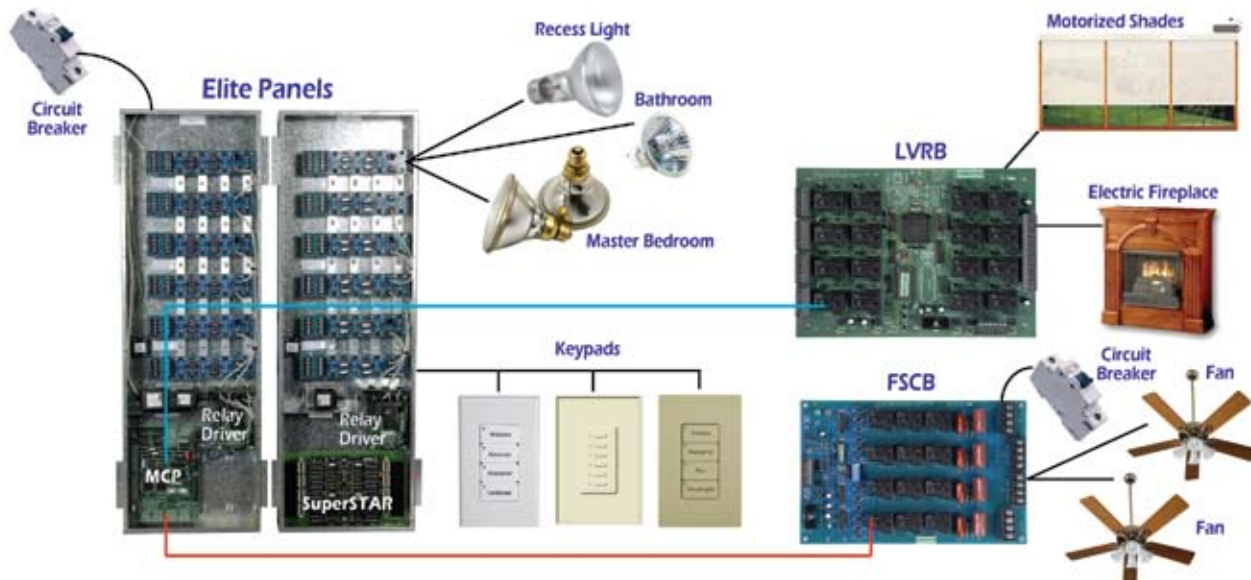

Centralite® manufactures residential and commercial lighting control solutions for new and existing construction. Our systems are designed to be simple, reliable, and affordable!

r.01.08 *Specifications subject to change

www.centralite.com 877.466.5483

©2008 All rights reserved

CENTRALITE
LIGHTING CONTROL SOLUTIONS