

## Product Data Sheet

# 3-Series Water Sensor

3315

Centralite®

Last Updated: April 2016

## Product Overview

Protect your home from expensive leaks and floods by installing a 3-Series Water Sensor near water heaters, drain pans, and underneath sinks. The Water Sensor is small, easy-to-use, and fits almost anywhere. Sit the sensor directly on the ground and it will notify you if it detects the presence of water.

## Dimensions

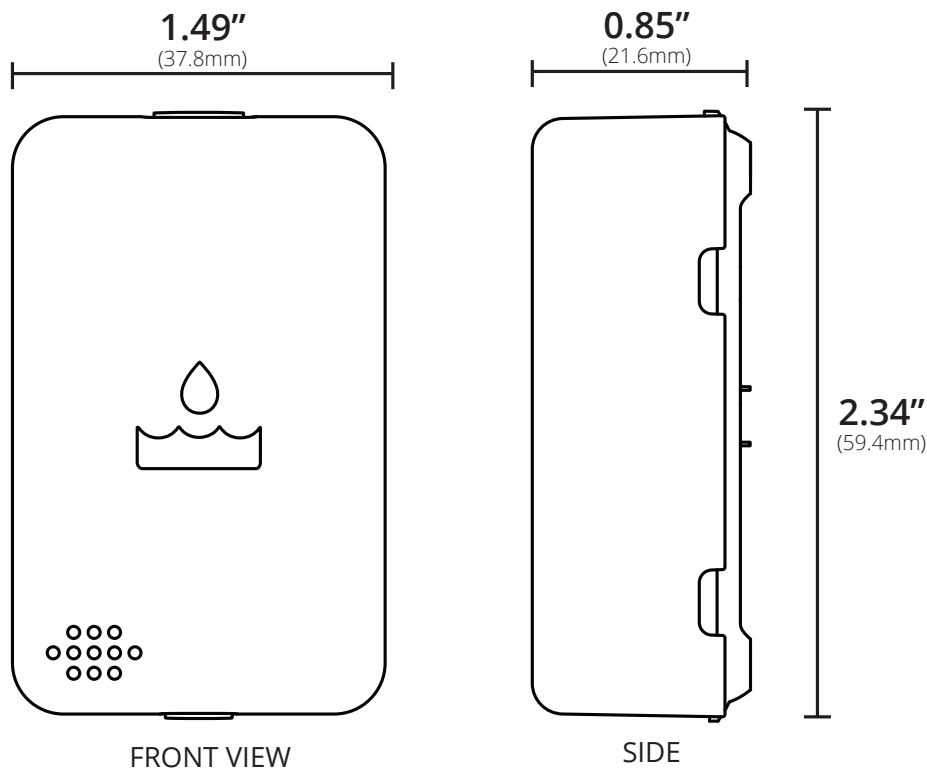

## In the Box:

- 1x - 3-Series Water Sensor
- 1x - CR-2 Battery
- 1x - Quick Start Guide

## Key Features:

- Detects as little as 0.5 ounces of water.
- Uses capacitance detection for sensitive and accurate detection.
- Water resistance ensures notification before damage to sensor occurs.
- Built-in power amplifier for exceptional range.
- Easy-to-install mounting plate for sensor.
- Easy compatibility with other manufacturers' ZigBee HA 1.2 devices.
- Pull-to-pair joining process.
- Over-the-air firmware updates.

## Use Cases

- Be alerted if an appliance or pipe is leaking or burst.
- Ensure that A/C drain pans don't overflow.
- Automatically shut off water supply to home in the event of a leak.
- Prevent basements from flooding if a sump pump fails.

### **Automatically shut off water supply to home in the event of a leak.**

If the 3-Series Water Sensor detects water, it can trigger a whole-home water shut off valve to disconnect the water supply. This protects your home against leak and flood damage even when you're away or unaware that there's a problem.

### **Ensure that A/C drain pans don't overflow.**

With the included clip-on standoff/remote leads, you can place the water sensor in areas that there is standing water. A/C drain pans contain some

water under typical operating conditions but with the 3-Series Water Sensor, you can be notified when the water reaches an unacceptable level.

### **Prevent basements from flooding if a sump pump fails.**

Many homes with basements have water issues requiring the use of an automatic sump pump to remove water. When these pumps fail, the rising water level can trigger notifications with the 3-Series Water Sensor.

---

## Special Features

### **Easy Placement**

The 3-Series Water Sensor can be placed on any non-conductive surface. It's as simple as joining and placing it in a low-spot or near an appliance such as a washing machine, refrigerator, or water heater.

### **Pull-to-Pair Join Process**

All 3-Series sensors feature "pull-to-pair" joining. The device ships with the battery pre-installed and all that is needed to begin the joining process is to pull out a small plastic tab from the bottom of the device. There is nothing for the user to take apart or put back together.

### **ZigBee Home Automation 1.2 Compatibility**

The 3-Series Water Sensor is fully ZigBee HA 1.2 certified and is guaranteed to function with all open, ZigBee HA 1.2-certified hubs and devices.

### **Superior Range and Updatability**

The 3-Series Water Sensor includes a built-in power amplifier, giving the module superior range and stability in large homes or areas with wireless interference.

The Water Sensor also supports over-the-air updates providing for seamless upgrades and feature additions without the need for any user interaction.

---

## Getting Started

### **Step 1: Open ZigBee Network for Joining**

Using your controller or hub's interface, enable the ZigBee network for joining.

### **Step 2: Pull Tab from Bottom of Sensor**

Pull the small plastic tab out of the bottom of the sensor and it will immediately begin searching for a network to join.

### **Step 2: Finish Joining at Hub (optional)**

Some hubs and controllers require additional steps such as naming or categorizing the device.

---

## Troubleshooting

### **Step 1: Remove and Replace Battery from Device**

Remove cover from sensor. Remove battery and replace with a new CR-2 battery. Reassemble and test operation.

### **Step 2: Factory Reset and Rejoin**

Remove cover from sensor and remove battery. While holding down the reset button, reinsert battery to factory reset the device. Repeat the "Getting Started" steps to rejoin the ZigBee network.

## Compatibility

The 3-Series Water Sensor features out-of-the-box compatibility with any ZigBee HA 1.2-certified hub, controller, bridge, or platform.

---

## Technical Specifications

### Power

Rated: 3V  
Battery: CR-2 (1x)  
Battery Life: 2 to 3 years

### Environmental

Operating Temperature: 0° to 40°C

### Shipping / Storage

Temperature: -20° to 50°C  
Humidity Range: 0 to 90% RH.  
(non-condensing)

### Approvals:



### Wireless RF

Protocol: ZigBee HA 1.2  
TX Strength: +18 dBm  
RF Channels: 16  
Range: 300+ ft. (90+ m) L.O.S.  
Temp Accuracy: ±0.4 °C (max), -10 to 85 °C

---

## Support

Centralite offers both Tier-1 and Tier-2 support structures to meet the needs of different customers. For those customers that provide existing, in-house support for systems, Centralite can serve as Tier-2 support specialists. For Centralite retail-branded products, Centralite provides direct Tier-1 support for all products.

## Standard Warranty

Centralite offers a standard 12-month limited warranty on the 3-Series Water Sensor.

Additional mandatory warranty period in compliance with local law product is being sold.

---

## Contact Sales

For more information about sales or distribution, please contact:

### North America

Sean Bryant, VP Sales & Marketing  
877-466-5483  
+1 251-607-9119 (Int'l)  
seanbryant@Centralite.com

Centralite Systems, Inc.  
1000 Cody Road  
Mobile, AL 36695

[www.Centralite.com](http://www.Centralite.com)

### International

Marco Dorjee  
International Business Development  
Office: +31 (0)20 893 2532  
Mobile: +31 (0)62 900 3903  
marcodorjee@Centralite.com

**Notice:** Any content, factual information, or specifications containing errors in this document are solely inadvertent and will be corrected upon discovery. Specifications for unreleased/planned products are subject to change.